

Understanding Ferrite-Filter Transmitter Combiners

By:
William F. Lieske, Sr.
Founder, EMR Corporation

Forward

EMR Corporation has been designing and building transmitter combining equipment for more than 19 years (as of February 1, 1980). The Ferrite-Filter type of combiner has become the mainstay of operations in commercial and public safety systems. Starting in 1983 development began in the 800-960 MHz ranges resulting in an unprecedented growth of 5, 10 and 20 channel transmitter combiners to serve "SMR" systems.

transmitters to a common antenna is more than 35 years old. Where two transmitters were spaced from each other by several MHz, it was possible to place one or more band pass cavities between each transmitter with a "tee" connector connected to the common antenna. Previously, hybrid couplers had been used to combine pairs of transmitters to a common output. (*Another bulletin titled "Hybrid Coupled Transmitter Combiner Systems" can be found in this group of technical papers.*)

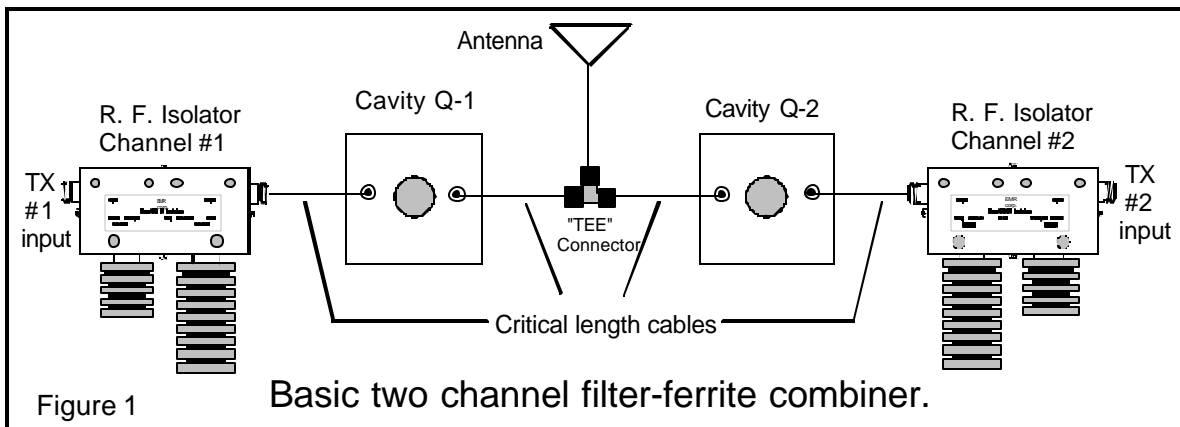

The design of this form of combiner is most often referred to as *Filter – Ferrite* since the major components are cavity filters and ferrite based isolators along with selected cables, connectors and hardware. First, we will review the nature of filter-ferrite combiners as an overview, then show how the various elements of this type of combiner contribute to the overall assembly.

History of the Design

The use of cavity resonators to tie two or more

When high quality, low loss R. F. isolators became available the idea of using cavities and isolators together to combine multiple transmitters evolved.

Since the hybrid coupler has more than 3 dB of loss in each branch, combining four, six or eight transmitters results in losses up to 10 dB in practice. By comparison, the filter ferrite type has much lower losses, leading to it being called "low loss" type by land mobile engineers and technicians.

Understanding Ferrite-Filter Transmitter Combiners

Figure 1 shows a basic two channel filter-ferrite combiner. A dual R. F. isolator feeds a band pass cavity in each branch. The outputs of the cavities are tied together with a “tee” connector for combining to a common antenna.

Provided that certain minimums of frequency spacing are observed, groups of five to ten (or more) transmitters can be combined in this manner, using a common *N-Way junction* with the antenna.

Cavity Resonators

The characteristics of the *band pass* cavities used in filter-ferrite combiners will determine the practical frequency spacing. As spacings become less the circuit “Q” of the cavities must be increased to yield acceptable power losses due to the combining process.

Note: A comprehensive discussion on cavity resonators titled “Understanding, Maintaining and Re-Tuning Duplexers” can be found beginning on page 16 of this publication.

The term “Q” denotes the figure of merit (e.g.: Quality) of the cavity. At a given radio frequency, the higher the “Q” the sharper will be the selectivity with a given amount of coupling through the cavity.

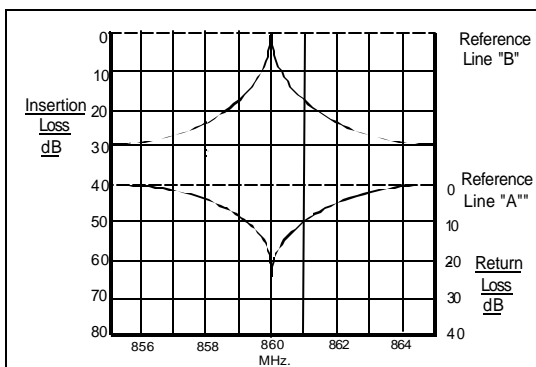

Figure 2 Response of single 7" square cavity
Set for 1.2 dB insertion loss, shown on 10 dB per division vertical resolution.

The throughput response and return loss of a typical 7" square or 8" round 3TEM⁽¹⁾ band pass cavity is shown in Figure 2. The cavity was adjusted for 1.2 dB loss. Note that at 1 MHz above or below the 860 MHz. frequency the cavity rejects signals by about 17 dB.

In Figure 3 we have superimposed a second filter system response over that in Figure 2, displaced by 1 MHz. Note that 17 dB of rejection is provided for both signals and that

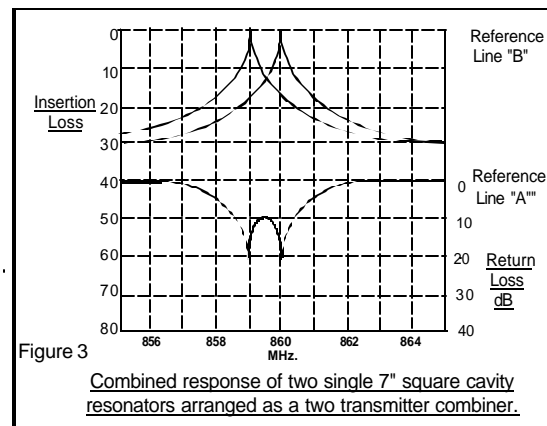

Figure 3

Combined response of two single 7" square cavity resonators arranged as a two transmitter combiner.

the return loss of each of the two cavities, when viewed from the antenna port, has 20 dB or better of return loss. The points where the response curve of one cavity crosses the pass frequency of the other cavity is important to consider. 17 dB down from a given power level is about 2% thus, with 100 watts applied to one cavity only 2 watts will be coupled into the other one.

Without further attenuation, however, this 2 watts mixed with the opposing carrier and or harmonics in the transmitter power amplifier stages would generate intermodulation products.

Elsewhere in this folder you will find a write-up called: “The Care And Feeding Of R. F. Isolators.” The theory of operation and per-

(1) 3TEM is a way to write 3rd transverse electromagnetic mode. This denotes a cavity with a resonator element length of ¼ wavelength.

Understanding Ferrite-Filter Transmitter Combiners

formance characteristics of isolators is covered in that write-up. You are urged to review it at this point.

Referring again to Figure 1, let us assume that 17 dB of attenuation is provided between channels at the 1 MHz spacing. Each dual stage isolator will provide 75 dB or more of additional attenuation, for a total of 92 dB or greater of channel to channel isolation.

Figure 4 displays the response of a given cavity resonator at three different coupling settings.

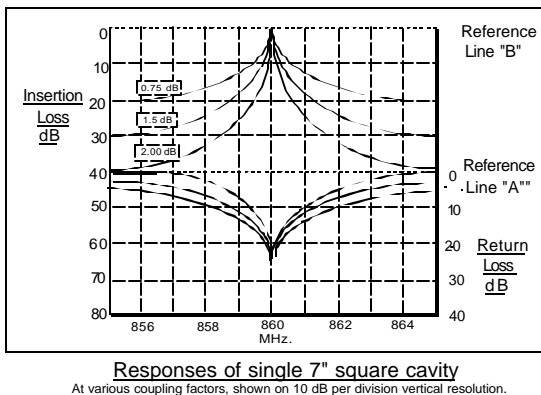

Figure 4

With a loss through the cavity of 0.75 dB, about 12 dB of attenuation is provided at 1 MHz, 16 dB at 1.5 dB and 25 dB at 2.0 dB coupling factors. It is important to determine that a reasonable compromise between adjacent channel coupling versus insertion loss is found to arrive at minimum loss along with needed intermodulation control.

Good practice in designing and tuning up filter ferrite combiners suggests that 3 dB of combining loss, from the isolator input to the antenna port, is the maximum, independent of band of operation. Although 3 dB loses $\frac{1}{2}$ the input power in the combining process, the benefits tend to make up for the effects of power loss.

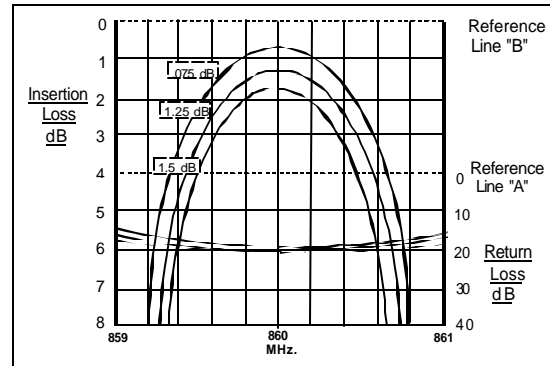

Figure 5 **Band pass cavity responses at different coupling factors**

Figure 5 shows the relative responses of the cavity nose characteristic curves at three coupling factors. The vertical resolution in this case is 1 dB per division for "B" channel and 10 dB per division for the "A" channel. Note that even with this resolution the selectivity narrows as coupling insertion loss increases.

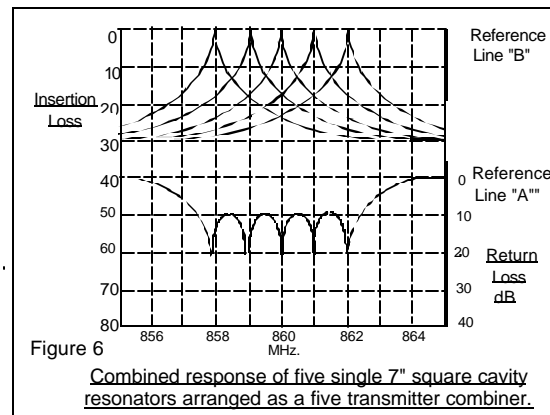

Figure 6 **Combined response of five single 7" square cavity resonators arranged as a five transmitter combiner.**

Figure 6 shows the responses of a five channel cavity manifold adjusted for 0.5 MHz channel to channel spacing.

The Star Junction

The layout shown in Figure 7 employs a five-way coaxial junction with a common antenna port. Since the junction is pentagonal in shape, it has come to be referred to as a "Star Junction." Used with proper cable lengths,

Understanding Ferrite-Filter Transmitter Combiners

according to frequency, cable type and connector characteristics a precise match between all cavity outputs and the antenna port may be accomplished.

This method of combining individual filter-ferrite channels together provides the most uniform insertion loss through all channels and a reasonably broad range of frequency spread. Tune-up is very straightforward once the cable lengths have been optimized.

The majority of transmitter combiners delivered by EMR Corporation use the Star Junction design.

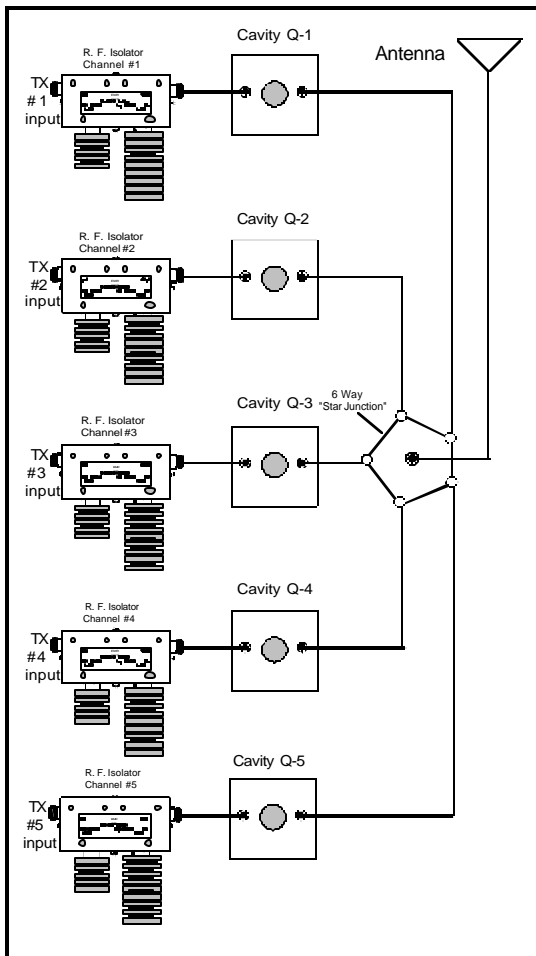

Figure 7 Star Junction Combiner

Line Segment Combiners

As shown in Figure 8, critical lengths of transmission line can be used to combine a number of filter – ferrite branches together. In this case a “tee” connector or a specially made rotatable coupling loop provides the means to chain the cavity outputs together.

It can be seen from the layout in Figure 8 that power accumulates along the string of line segments which are fine tuned by a shorted stub at the end opposite to the antenna. Usually the channel losses are slightly higher at the frequency nearest the stub end of the

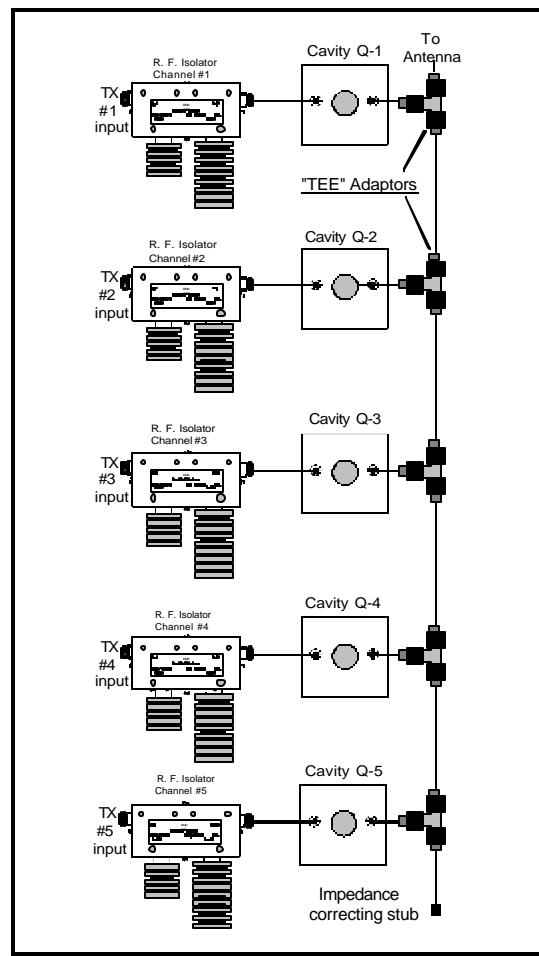

Figure 8 Line Segment Combiner

Understanding Ferrite-Filter Transmitter Combiners

line due to the accumulated line and connector losses. Moreover, the individual channel input powers accumulate. Attention to cable and connector ratings must be paid to prevent connector failures. Special adapting devices are sometimes built to handle larger cable and carry the accumulated R. F. currents present when all channels are active.

Star and Line Segment Comparisons

When properly designed and tuned both combiner types have similar performances when the same types of isolators and cavity resonators are used. The Star Junction type will usually have a more uniform *per channel* insertion loss and through the use of a special connector such as a 7/16" DIN or other high power rated connector it is quite possible to safely handle up to 200 watts per channel in a five channel, 800 MHz band SMR combiner.

Need More Channels?

Both combiner types can be expanded to add one or two channels, provided that frequency spacings are suitable. This is mostly a matter of mechanics, since most popular licensed frequency allocations are in groups of five, spaced uniformly at 0.5 or 1.0 MHz increments. Some systems use non-sequential frequencies, as FCC licensed. The minimum spacing between adjacent channels must be considered in the combining plan.

Since the most suitable cable lengths, particularly in the 800 MHz band, are relatively short in both designs (8 -10 inches in length), a practical arrangement of the cavities and isolators is often very difficult to devise when adding channels to an existing system.

Some combiner manufacturers feature "field expandable" combiners. However, unless the user's technical capabilities and instrumentation is adequate, the combiner

must be returned to the factory for expansion and re-optimization to insure proper long term performance.

More About Channel To Channel Spacings

Looking back at Figures 4, 5 and 6 note that there is some practical minimum transmitter to transmitter frequency spread that can be used. There are several reasons for this. First, as channel spacings become smaller, the cavities must be de-coupled to provide sufficient selectivity to prevent coupling more than just a small amount of power to adjacent channels. As the cavities are de-coupled for higher loss the "nose" selectivity becomes sharper as does the return loss curves. When a multi-channel combiner is properly optimized, each combined channel will "see" a 50 Ω impedance at the antenna port. The combining process employs a complex network to accomplish this.

Antennas and transmission lines change over time. Ice loading on antennas, moisture or even the wind swaying a side mounted antenna near a tower leg can cause changes in the antenna's VSWR. Every antenna begins to degrade the day that it is installed and its performance is reduced over time by the ravages of wind, rain, ice and exposure to the sun's rays. Even the coaxial cable to the antenna will have some shift in velocity factor and the dielectric constant of the insulation will change measurably from below zero to over 100 degrees F.

When these things occur, the true impedance of the driven end of the transmission line can and will vary enough to reflect a change in loading on the combiner. The point that we wish to make, here, is that when spacings are very close, a change in impedance match will occur. This is manifested in power being reflected in some phase relationship other than that which provides a suitable match with

Understanding Ferrite-Filter Transmitter Combiners

the entire system. This “pulls” the cavity resonators out of tune, enough to move their peaks toward (or even on) adjacent channels.

Often in public safety VHF systems we find irregular groups of channel frequencies to be combined. The rules to follow are:

For this reason, filter ferrite combiners set too

1. Be sure that the antenna to be used has

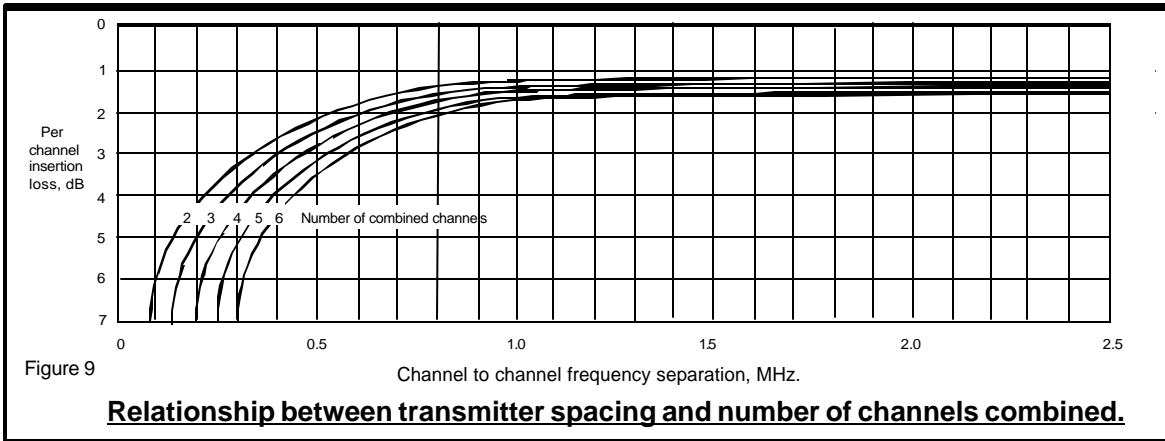

close in channel to channel spacing become erratic, require constant maintenance and often cause failure of connectors, cavities and isolators resulting from changes in the antenna and transmission line.

sufficient bandwidth to provide a usable VSWR from the lowest through the highest channel frequency. Try to avoid antennas that are rated to a VSWR of 1.5:1 by their manufacturer.

An appendix is provided at the end of this write-up in which we suggest the minimum practical frequency spacings according to operating band, transmitting power and number of combined frequencies.

2. If possible, select frequencies for combining that are spaced at least 200 KHz in the 150-174 MHz range, 300 KHz in the 450-470 MHz range and 500 KHz in the 800-960 MHz range.

Practical Maximum Frequency Spacings

3. Where a given group of frequencies are spaced such that combining all of them to a single antenna will result in unacceptable losses for one or more channels it is better to use a second antenna, choosing channels according to best spacing.

We have discussed minimum spacings between combiner frequencies and it follows that the maximum frequency spacings must also be considered. This is particularly true when designing a combiner for three or more channels having a random pattern of frequency.

Some Combining Examples

Figure 9 shows what happens as more and more channels are combined. Note that as frequency spacings are made less, loss goes up. Also, as channels are added, losses will increase.

Suppose that we have a group of 12 UHF frequencies that are to be combined in the best, most suitable manner. The frequencies are:

T1-461.025 MHz	T7-463.925MHz
T2-461.100	T8-464.350

Understanding Ferrite-Filter Transmitter Combiners

T3-463.150	T9-464.375
T4-463.200	T10-464.500
T5-463.550	T11-464.675
T6-463.825	T12-464.975

This frequency list is typical of a group of "business radio" channels that are to be trunked under the current "re-farming" rules. We want to keep the per channel signal levels as uniform as possible to ensure equal channel access.

We sort the twelve frequencies into three sub groups, each group having at least 300 KHz of offset from adjacent frequencies. We determine that we will use three antennas and transmission lines. The combined groups are:

<u>Group #1</u>	T1-461.025 MHz
	T2-463.150

<u>Group #2</u>	T1-461.100 MHz
	T2-463.200
	T3-463.925
	T4-464.500

<u>Group #3</u>	T1-463.550 MHz
	T2-464.350
	T3-464.675
	T4-464.975

The logic used in this combining plan is the result of using the least number of channels meeting reasonable (under 3 dB) losses in each group. Using this deployment of frequencies, the losses would range from 2.4 to just under 3 dB, providing transmit levels that are with 0.6 dB in strength.

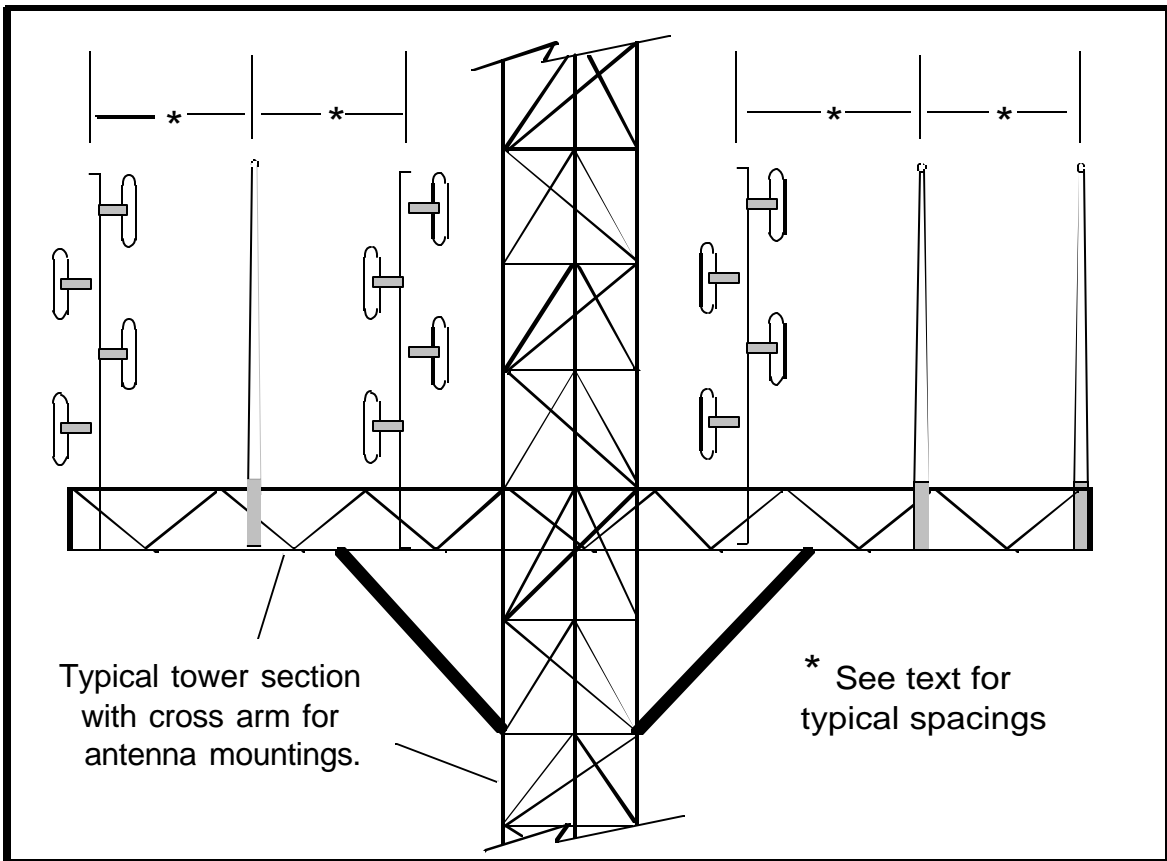

Figure 10 Horizontally Mounted Transmitting Antennas

Understanding Ferrite-Filter Transmitter Combiners

Combiner Antenna Adjacencies

In the 12 channel frequency combining example where do we locate the three antennas with respect to each other? In EMR Corp's catalog, and many others, you will find nomographs that give isolation vs: separation between antennas spaced both vertically and horizontally.

We use the vertical (also called collinear) spacing to good advantage to separate receiving antennas from transmitting antennas in combining-multicoupling arrangements. It is most desirable to have all transmitting antennas that can be accessed by a particular mobile unit on the same, or nearly the same plane to maintain a proper height-gain relationship. We can locate these antennas horizontally opposed from each other at distances that will result in 20 dB (1%) or less of induced coupling between them. This isolation adds to that provided by the isolator-cavity combination in each combiner path, usually adding up to more than 100 dB of signal coupling for adequate protection from I. M. problems.

For multi-element and collinear "gain" antennas, the following distances are suggested:

<u>Frequency Band</u>	<u>Spacing (*)</u>
66-88 MHz	48' min.
140-175 MHz	32' min.
450-470 MHz	20-24'
806-864 MHz	16-18'
827-960 MHz	See note:

Remember that reflections from towers, guy wires and other antennas will modify the coupling factor. It is a good idea to actually measure and record each coupling to be assured that at least 20 dB of de-coupling is present. Note: Steps must be taken to

separate the antennas enough to secure the 20 dB or more of de-coupling.

Installation Notes

With certain exceptions, all filter ferrite combiners are shipped from the factory in a fully tuned and optimized condition. The exceptions are assemblies to be held as spares or stocked by distributors, in which case their technicians perform the necessary tuning services. If not subjected to shipping damage, most combiners are ready to cable up and place in service. Unless specifically instructed by the manufacturer, no field adjustments should be necessary and none should be attempted.

Maintaining Combiners and Systems

We have had combiners returned to us for re-tuning to different frequencies after daily operation for 8 to 10 years and found them to be within tenths of dB's in performance characteristics. Unless something untoward occurs, this type of combiner does not need a scheduled "tweaking" or tune-up.

If, however, there is evidence of system problems, such as isolator load terminations running warm or hot the antenna system is probably in trouble, reflecting power back to the combiner. To verify this, place a portable wattmeter between the combiner output and the antenna feed line and key up each transmitter (one at a time) and observe both forward and reflected powers. It is quite possible for an antenna to partially fail such that different reflected powers are present within the range of the combined frequencies.

If a small amount of reflected power is present and the power out of the combiner is sub-

* See Figure 10

Understanding Ferrite-Filter Transmitter Combiners

standard on a given channel, either the cavity has drifted, was inadvertently de-tuned or was damaged by lightning (Yes, this does happen!). Isolators can also fail from exceeding their safe power input rating or from long operation with high reflected power, damaging load terminations. Connectors and cables can also be damaged by lightning.

An integral power monitoring system will be an asset in system management, particularly one that provides monitoring important power levels via a modem and computer read-out.

Frequency Changes

It often occurs that one or two channels out of a combined group must be re-tuned. Channel frequencies of filter-ferrite combiners may be changed provided that certain guidelines are followed. These include:

1. Make sure that the new frequency for the channel meets the minimum spacings (See Appendix 1).

2. If you will be changing to another frequency that is within 2% or less of the old one and the frequency is within the minimum range from any other existing channel frequency you should be able to simply apply low power to that channel input and re-tune the cavity for maximum output to the antenna. Example: Old frequency 153.20 MHz, new frequency to be 155.025 MHz). Difference is 1.825 MHz or about 1.2% of the new channel frequency.

3. Isolator responses are relatively broad. However, if a frequency change of up to 2% of band frequency is done, a touch-up of isolator tuning can be done.

Appendix #1: Minimum frequency Spacing Between Combined Channels

Frequency Range	Cavity Size, Type	Minimum Spacing	Maximum Spacing	Comments
66-88 MHz.	4" Sq. or 5" Round	0.150 MHz.	4 MHz.	100 watt input power
150-174 MHz.	4" Sq. or 5" Round	0.200 MHz.	6 MHz.	150 watt input power
150-174 MHz.	7" Sq. or 8" Round	0.175 MHz.	6 MHz.	To 250 watts input (1)
406-455 MHz.	4" Sq. or 5" Round	0.450 MHz.	10 MHz.	Fed. Gov't & Amateur
406-455 MHz.	7" Sq. or 8" Round	0.275 MHz.	12 MHz.	Fed. Gov't Amateur
450-470 MHz.	4" Sq. or 5" Round	0.400 MHz.	10 MHz.	Business & Industrial
450-470 MHz.	7" Sq. or 8" Round	0.300 MHz.	12 MHz.	Business & Industrial
851-869 MHz.	4" Sq. or 5" Rd. TEM1	1.500 MHz.	15 MHz.	Low power SMR Control Sta.
851-869 MHz.	7" Sq. or 8" Rd. TEM3	0.500 MHz.	18 MHz.	SMR - Trunking Systems
928-931 MHz.	7" Sq. or 8" Rd. TEM3	0.600 MHz.	5 MHz.	High Power Paging (2)
940-945 MHz.	7" Sq. or 8" Rd. TEM3	0.700 MHz.	5 MHz.	SMR - Trunking Systems

(1) Requires 250 watt isolators and cooling package for high duty cycles.

(2) Models up to 500 watts input per channel. Thermal management necessary.